

CERWIN-VEGA

The **LOUD** Speaker Company®

CVXL SERIES MANUAL

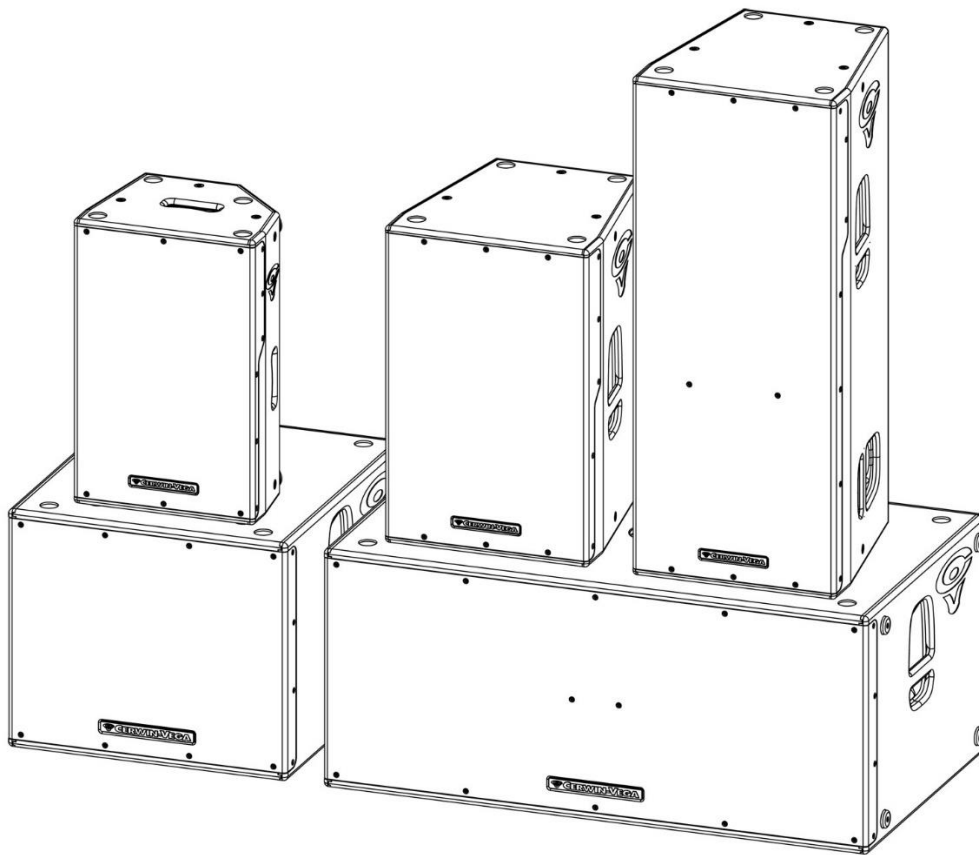

CVXL-112, CVXL-115, CVXL-215, CVXL-118s, and CVXL-218s **Powered Loudspeakers**

Instruction Manual (English)

To avoid injury, read all operating instructions and safety information in this manual before using the speaker.

Failure to follow these safety instructions could result in fire, electric shock, other injury or damage to the speaker or other property.

Contents

IMPORTANT SAFETY INSTRUCTIONS.....	3
REGULATORY CERTIFICATION	5
Introduction	6
Before you begin.....	6
Quick Start.....	7
Loudspeaker Placement.....	7
Rear Panel - Mixer - CVXL-112, CVXL-115, CVXL-215.....	8
Rear Panel - Mixer - CVXL-118s, CVXL-218s.....	10
CVXL Power Connections - Rear Panel.....	12
Using the CVXL-112 as a floor/stage monitor.....	13
Using the pole mount - CVXL-112, CVXL-115 only.....	14
Using suspension points - CVXL-112, CVXL-115, CVXL-215 only.....	15
Application #1 - Single CVXL-112, CVXL-115, or CVXL-215	17
Application #2 - Adding a second CVXL-112, CVXL-115, or CVXL-215	18
Application #3 - Adding a Subwoofer	19
Application #4 - Adding Two Subwoofers.....	20
Application #5 - Subwoofer Cardioid Mode - Two Subwoofers.....	21
Application #6 - Subwoofer Cardioid Mode - Three Subwoofers	22
Application #7 – Daisy-Chain	23
Application #8 – Adding a CVXL-112 as a Stage Monitor.....	24
Application #9 – Large Venue/Front of House.....	25
Protective Grill	26
Remote Main Volume	26
Troubleshooting.....	27
Care and Maintenance.....	29
Cable Connections	29
Warranty	31
How to Obtain Warranty Service	33

IMPORTANT SAFETY INSTRUCTIONS

 **CAUTION:** The lightning flash with an arrowhead symbol within an equilateral triangle is intended to alert the user to the presence of uninsulated dangerous voltage within the unit's enclosure that may be of sufficient magnitude to constitute a risk of electric shock.

 **WARNING:** The exclamation point within an equilateral triangle is intended to alert the user to the presence of important operating and maintenance (servicing) instructions in the literature accompanying the product.

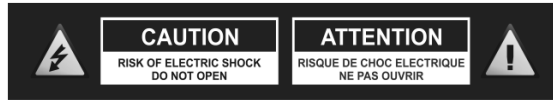

 **NOTE:** The hand within an equilateral triangle is intended to alert the user to specific guidance and information regarding the operation of the unit and should be read fully before using the unit for the first time.

-  a) Read and follow all the safety and operating instructions before connecting or using this product.
 b) Retain this user manual for future reference.
 c) All warnings on the unit and its packaging should be read and followed.

 **CAUTION:** To reduce the risk of fire or electric shock, do not expose this product to rain, moisture, dripping, or splashing. Do not place objects containing liquid (such as vases or glasses) on the unit. Do not use this product near water, such as a bath tub or swimming pool. Unplug the unit from the wall outlet before cleaning. Never use thinner, cleaning fluids, solvents, or chemically impregnated cloths. For cleaning, always use a soft dry cloth. Unplug the unit during lightning storms or when it is unused for long periods of time.

 **CAUTION:** The unit should be installed so that its location or position does not interfere with its proper ventilation. For example, it should not be situated on a bed, sofa, rug, or similar surface that may block the ventilation openings. It should not be placed within a built-in installation (such as a bookcase or cabinet) that may impede the flow of air through its ventilation openings and/or fan assembly. The unit should be situated away from heat sources such as radiators, heat registers, stoves, or other devices (including amplifiers) that produce heat. Naked flame sources, such as lighted candles, should not be placed on or near the unit.

 **WARNING:** Do not place the unit on an unstable surface, cart, stand, tripod, bracket, or table. The unit may fall, causing serious injury to a person and serious damage to the unit. Use only with a cart, stand, tripod, bracket, or table recommended by the manufacturer. Any mounting of the device on a wall or ceiling should follow the manufacturer's instructions and should use a mounting accessory recommended by the manufacturer. An appliance and cart combination should be moved with care. Quick stops, excessive forces, and uneven surfaces may cause the appliance and cart combination to overturn. When a cart is used, use caution when moving the cart/unit combination to avoid injury from tipping.





 **NOTE:** Should the unit become damaged beyond repair or reach the end of its life, please consult the regulations regarding disposal of electronic products in your region.

 **NOTE:** Cerwin-Vega cannot be held responsible for damage caused by improper use of the unit and/or the applications provided for use with the unit.

 The unit shall be connected to a mains socket outlet with a protective ground (earth) connection.

IMPORTANT SAFETY INSTRUCTIONS (continued)

- 
1. The unit and power supply should only be connected to a power outlet that matches the voltage and frequency marked on the rear of the unit.
 2. Protect the power cable from being walked on or pinched, particularly at plugs, convenience receptacles, and exit points on the unit.
 3. Do not defeat the safety purpose of the polarized or grounding-type plug. A polarized plug has two blades with one wider than the other. A grounding-type plug has two blades and a third grounding prong provided for your safety. If the provided plug does not fit into an outlet, consult a qualified electrician for replacement of the obsolete outlet.
 4. If the mains plug supplying this product incorporates a fuse, then the fuse should be replaced only with one of identical or lower rupture value.
 5. Never use a damaged or frayed power cable; this can cause risk of exposure to lethal voltages.
 6. The power cable of the unit should be unplugged from a wall outlet when it will not be used for a long period of time.
 7. Only use attachments/accessories specified by the manufacturer.
 8. To completely disconnect the power input, the mains plug of the speaker should be disconnected from the mains connection.
 9. The mains plug of the unit should not be obstructed, so that it can be easily accessed during intended use.



CAUTION: To reduce the risk of fire or electric shock, do not remove any covers or open the unit. There are no user-serviceable parts inside. **DO NOT ATTEMPT SERVICING OF THIS UNIT YOURSELF. REFER TO QUALIFIED SERVICE PERSONNEL FOR SERVICING.**

- 
- The unit should be serviced by qualified service personnel when any of the following happens:
- The power cord or the plug has been damaged.
 - Objects have fallen onto or liquid has been spilled into the unit.
 - The unit has been exposed to rain or liquids of any kind.
 - The unit does not appear to operate normally or exhibits a marked change in performance.
 - The device has been dropped or the enclosure has been damaged.



Keep speakers out of extended or intense direct sunlight; the driver suspension could prematurely dry out, and finished surfaces may become degraded.



The speaker contains sensitive components. Do not drop, disassemble, open, crush, bend, deform, puncture, microwave, incinerate, paint, or insert foreign objects into speaker.



The speaker is easily capable of generating sound pressure levels (SPL) sufficient to cause permanent hearing damage. Caution should be taken to avoid prolonged exposure to SPL in excess of 90 dB(A).



Operate and store the speaker in a place where the temperature is between -20° and 55°C (-4° and 131°F). Low or high temperature conditions might cause the speaker to temporarily stop working. Avoid dramatic changes in temperature or humidity when using the speakers, as condensation may form within the speaker.



Turn the speaker off when in any area with a potentially explosive atmosphere. Obey all signs and instructions, as sparks in such areas could cause an explosion or fire resulting in serious injury or death. Areas with potentially explosive atmosphere are often, but not always, marked clearly. Potential areas include fueling stations, areas where the air contains chemicals or partials (including grain dust or metal particles), below deck on boats, and chemical transfer storage facilities.



The speaker contains small parts which may present a choking hazard to small children. Keep the speaker and its accessories away from small children.

REGULATORY CERTIFICATION

Cerwin-Vega declares under sole responsibility that this product, to which this declaration relates, is in conformity with the following standards:



This device complies with Part 15 of the FCC Rules. Operation is subject to the following two conditions: (1) this device may not cause harmful interference, and (2) this device must accept any interference received, including interference that may cause undesired operation.



WARNING: Changes or modifications to this unit not expressly approved by the party responsible for compliance could void the user's authority to operate the equipment.



NOTE: This equipment has been tested and found to comply with the limits for a Class B digital device, pursuant to Part 15 of the FCC Rules.

These limits are designed to provide reasonable protection against harmful interference in a residential installation. This equipment generates, uses, radiates radio frequency energy, and, if not installed and used in accordance with the instructions, may cause harmful interference to radio communications. However, there is no guarantee that interference will not occur in a particular installation. If this equipment does cause harmful interference to radio or television reception (which can be determined by turning the equipment off and on), the user is encouraged to try to correct the interference by one or more of the following measures:

- Reorient or relocate the receiving antenna.
- Increase the separation between the equipment and receiver.
- Connect the equipment into an outlet on a circuit different from that to which the receiver is connected.
- Consult the dealer or an experienced radio/TV technician for help.

This Class B digital apparatus complies with Canadian ICES-003.

Introduction

Congratulations! Welcome to the Cerwin-Vega family! You've joined a growing group of audio professionals who have turned to Cerwin-Vega for the most advanced audio reproduction systems available. All Cerwin-Vega products are thoroughly tested to ensure that they meet or exceed our performance specifications. Backed by the best service in the industry, Cerwin-Vega is dedicated to quality and reliability. For a complete overview of Cerwin-Vega products and services, visit www.cerwin-vega.com

Before you begin

This manual covers the CVXL-Series active speakers: the CVXL-112, CVXL-115, and CVXL-215 (referred to as "tops") and the CVXL-118s and CVXL-218s (referred to as a "subs"). These speakers are designed for portable applications (such as being mounted on a tripod stand or pole mount or stacked directly on a floor, stage, or stable platform) and fixed installations (such as being "flown" or suspended using appropriate wall/ceiling mounting hardware). These speakers are not intended for fixed installation in high-moisture or outdoor environments, as moisture can cause corrosion of electrical contacts and damage the speaker cone or surround. Cerwin-Vega does not support suspension of the subwoofer models covered in this manual.

Cerwin-Vega speakers can generate considerable vibrational energy. When placed on a slippery surface such as polished wood or linoleum, the speaker may move due to its own mechanical vibration. Precautions should be taken to assure that the speaker does not fall off a stage or table when in operation.

The CVXL-118s and CVXL-218s subwoofers include a receptacle cup to allow mounting of a satellite speaker using a standard speaker pole shaft. When using a standard speaker pole shaft, be sure to observe the following precautions:

- There are many types of pole stands and pole shafts available. Please refer to qualified service personnel from the pole stand and pole shaft manufacturers for installation service. Improper use of accessories or inappropriate installation could present a hazard.
- Check the speaker pole shaft specification to be certain it is designed to support the weight of the speaker.
- Observe all safety precautions specified by the speaker pole shaft manufacturer.
- Always verify that the subwoofer is placed on a surface that is flat, level, and stable.
- Route cables so that they will not be tripping hazards.
- Always be cautious in windy outdoor conditions, as the stability of the entire system may be compromised.

Quick Start

The steps below provide a quick reference on how to set up and use a single loudspeaker. A typical setup will follow the same basic steps.

STEP 1	<ul style="list-style-type: none"> ✓ Make sure the loudspeaker is unplugged from the AC mains. ✓ Be sure the power switch is set to the OFF position. ✓ Turn the LEVEL knob to the lowest level (fully counterclockwise).
STEP 2	<ul style="list-style-type: none"> ✓ Place the loudspeaker in the intended location. ✓ Connect the source audio equipment OUTPUT to the loudspeaker INPUT. Be sure the source equipment is powered on and set to a normal output level.
STEP 3	<ul style="list-style-type: none"> ✓ Connect the power cord to the loudspeaker and AC power outlet. ✓ Set the POWER switch to the ON position and verify the POWER LED indicator is illuminated. ✓ Slowly turn the LEVEL knob clockwise until the sound output is at the desired level. If there is no sound, check to make sure that the source equipment is providing audio output.
NOTES	<p>When you are finished using the loudspeaker, set the POWER switch to the OFF position <u>BEFORE</u> removing any cables or turning off the source audio equipment.</p>

Loudspeaker Placement

- Never point a microphone directly at the loudspeaker, as this will result in feedback (unwanted sound). Be sure the loudspeaker is placed away from the front of a microphone or directly behind a microphone when it is in a floor monitor position.
- When used with turntables, the loudspeaker should be carefully placed so that any vibrations do not interfere with the turntable performance and functionality.
- Avoid placing the loudspeaker in corners or along the walls of a room. Doing so will increase the low-frequency sounds, which will result in a muddy and incoherent sound reproduction.
- Avoid placing the speaker directly on a hollow stage. It is better to place the loudspeaker on a tripod stand or a sturdy table.
- The loudspeaker should be placed two to four feet above the ear level of the audience since the human body can absorb sound, especially at high frequencies. This will ensure that the entire audience can hear the sound system with the best possible clarity.

Rear Panel - Mixer - CVXL-112, CVXL-115, CVXL-215

INPUT 1, INPUT 2, INPUT 3 GAIN KNOBS

Each knob adjusts the gain level on the respective input signal. The full clock-wise position (MAX) sets the gain level to maximum whereas a full counter-clockwise (MIN) position sets the gain level to the minimum 'MUTE' level. It is recommended to set each level knob to the middle position and the Main Level knob to the MIN or fully counter-clockwise position when first connecting the system.

INPUT 1, INPUT 2 MIC/LINE SWITCHES

Set each switch according to the equipment connected to INPUT 1 and INPUT 2. For example, if a microphone is connected to INPUT 1, set the switch to 'MIC'. If a mixing console or acoustic-electric guitar is connected then set the switch to 'LINE'.

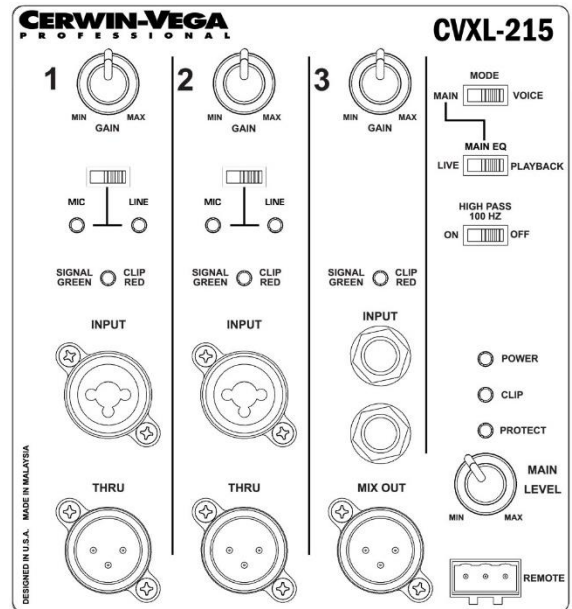

NOTE: The input switch must be properly set to the device that is connected to the input. Any mistake may result in unexpected sound level.

SIGNAL/CLIP INDICATORS

Each of the three inputs is monitored by an indicator that provides status on the incoming audio signal. The SIGNAL indicator is illuminated when there is an audio signal present with a level greater than -30dBu. The CLIP indicator is illuminated when the audio signal is clipping and adjustments must be made to avoid amplifier shutdown and poor sound quality. Adjustments to prevent clipping are made by reducing the input signal gain/level on the appropriate channel or reducing the volume level on your audio source, if possible.

INPUT 1 & INPUT 2 INPUT JACKS

A combination input on each channel allows for either XLR or 1/4" TRS cable types.

INPUT 3 INPUT JACKS

A pair of 1/4" TS unbalanced input jacks is provided on this channel for stereo connections such as a keyboard or media device. Devices with RCA outputs can use these inputs with the appropriate cable or plug adapter. Both input jacks on this channel are summed into one mono signal.

THRU 1 & THRU 2

The balanced XLR outputs THRU 1 & THRU 2 are parallel connections to the respective INPUT 1 and INPUT 2. The level controls for INPUT 1 & INPUT 2 will not affect the signal on the direct output connection.

MIX OUTPUT

This is a balanced XLR output that is a sum of all three input channels. This output is not affected by changes to the Main Level knob or the custom features but is affected by the levels set on each channel gain knob. This connection is designed to provide an output which combines all three input channels together for connecting to another CVXL powered speaker or a recording device.

MAIN LEVEL KNOB & REMOTE VOLUME CONTROL

It is highly recommended to have the volume set to the minimal (MIN) level upon initial system start-up and it can be adjusted two different ways. On the Main Level knob, volume is increased in a clockwise rotation and decreased in a counter-clockwise rotation. Another method to control the volume is by using the Remote connection (sold separately). A removable three-terminal jack can be wired over long distances to a remote volume control device with a corresponding connection.

INDICATORS

Three indicators provide operating condition status on the CVXL-112, CVXL-115, or CVXL-215:

- 1) The POWER indicator (green) will illuminate when power is properly applied and the main power switch is 'ON'.
- 2) The CLIP indicator (yellow) will illuminate when the sound output is near the maximum and automatically reduced to prevent damage to the speaker. In such a condition, it is suggested to reduce the volume level so the CLIP indicator does not illuminate. Continued use, while this indicator is illuminated, may result in a protect condition where no sound can be produced.
- 3) The PROTECT indicator (red) will illuminate when a fault occurs and the speaker automatically places itself into a condition where sound output is shut off. This condition may be the result of excessive clipping, excessive heat, or low voltage. These conditions all can cause significant damage to the product.

CUSTOM FEATURES

MODE

The MODE switch adjusts the contour of the overall frequency response optimizing the speaker for use as either a stage monitor (CVXL-112), for vocal reinforcement (CVXL-115, CVXL-215), or a main sound system (CVXL-112, CVXL-115, CVXL-215). When set to 'MAIN', the response is controlled by the MAIN EQ switch described below. When set to 'MONITOR' on a CVXL-112, the mid-range and sub-low frequencies are attenuated which helps increase focus on the low and high frequencies while potentially reducing feedback and muddiness. When set to 'VOICE' on a CVXL-115 or CVXL-215, the high and low frequencies are slightly attenuated allowing for better intelligibility when used as a PA (public address) system. It is recommended that users listen to their system with this switch in either setting to determine what is best for their needs.

MAIN EQ

The MAIN EQ switch adjusts the contour of the overall frequency response optimizing the speaker for use as either a main PA speaker or for playback of recorded music. When set to 'LIVE', the response is optimized for using the speaker as a PA (public address) or sound reinforcement system. When set to 'PLAYBACK', low frequencies are increased and mid frequencies are decreased to enhance pre-recorded music. These settings are ideal for situations where an external mixer or EQ device is not available or for playback only situations such as mobile DJ's.

HIGH PASS 100 Hz

When engaged to 'ON', the HIGH PASS 100 Hz switch attenuates overall frequency output below 100 Hz. This is recommended to reduce stage rumble when the speaker is used as a floor monitor or in situations where low frequencies need to be attenuated such as in combination with a subwoofer.

Rear Panel - Mixer - CVXL-118s, CVXL-218s

SIGNAL/CLIP INDICATOR

Each of the two inputs is monitored by an indicator that provides status on the incoming audio signal. The SIGNAL indicator is illuminated when there is an audio signal present with a level greater than -30dBu. The CLIP indicator is illuminated when the audio signal is clipping and adjustments must be made to avoid amplifier shutdown and poor sound quality. Adjustments to prevent clipping are made by reducing the input signal gain/level on the appropriate channel or reducing the volume level on your audio source, if possible.

INPUT 1 & INPUT 2 INPUT JACKS

A combination input on each channel allows for either XLR or ¼" TRS cable types.

THRU 1 & THRU 2

The balanced XLR outputs THRU 1 & THRU 2 are high pass filtered from the respective INPUT 1 and INPUT 2 connectors. The crossover frequency of the high pass filtering is determined by the position of the CROSSOVER FREQUENCY switch.

LINK OUTPUT

This is a balanced XLR output that is the sum of the two input channels. This output is not affected by changes to the Main Level knob or the custom features. This connection is designed to provide an output which combines both input channels together for connecting to an additional powered speaker.

MAIN LEVEL KNOB & REMOTE VOLUME CONTROL

It is highly recommended to have the volume set to the minimal (MIN) level upon initial system start-up and it can be adjusted two different ways. On the main volume knob, volume is increased in a clockwise rotation and decreased in a counter-clockwise rotation. Another method to control the volume is by using the Remote connection (sold separately). A removable three-terminal jack can be wired over long distances to a remote volume control device with a corresponding connection.

INDICATORS

Three indicators provide operating condition status on the CVXL-118s and CVXL-218s:

- 1) The POWER indicator (green) will illuminate when power is properly applied and the main power switch is 'ON'.
- 2) The CLIP indicator (yellow) will illuminate when the sound output is near the maximum and automatically reduced to prevent damage to the speaker. In such a condition, it is suggested to reduce the volume level so the CLIP indicator does not illuminate. Continued use, while this indicator is illuminated, may result in a protect condition where no sound can be produced.
- 3) The PROTECT indicator (red) will illuminate when a fault occurs and the speaker automatically places itself into a condition where sound output is shut off. This condition may be the result of excessive clipping, excessive heat, or low voltage. These conditions can cause significant damage to the product.

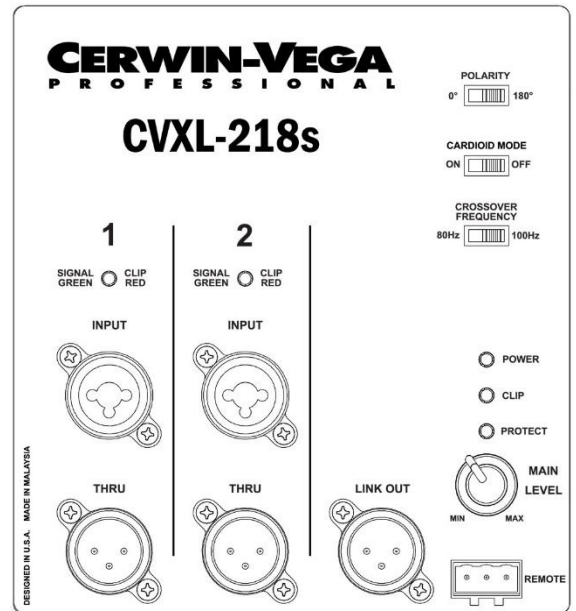

CUSTOM FEATURES

POLARITY REVERSE

In situations where the CVXL-118s or CVXL-218s is not optimally located, a polarity reverse switch is provided which inverts the audio signal by 180 degrees and can improve low frequency performance. In certain situations, the location of the subwoofer may be out of phase with the full-range speakers. By reversing the polarity of the subwoofer, the phase will match the full-range with the benefit of not having to relocate the subwoofer.

CARDIOID MODE

When using multiple subwoofers in stacks or side by side, cardioid sub units can be turned backward to face the stage and switched to CARDIOID MODE. This will reduce the volume of the subwoofers for the performers on stage, while still projecting good low frequency coverage toward the audience. This is particularly beneficial when the subwoofers are placed relatively close to performers in high volume level settings.

CROSSOVER FREQUENCY

This switch selects the crossover frequency of two simultaneous filters; the low pass filter for the subwoofer and the high pass filter of the THRU 1 & 2 outputs. For smaller setups, it is recommended to connect the source output (such as a mixing board) to the subwoofer INPUT 1 and INPUT 2 connectors and the inputs of other powered full range loudspeakers (such as the CVXL-112, CVXL-115, or CVXL-215) to the subwoofer THRU 1 & 2 outputs for a more balanced and pleasing sound.

CVXL Power Connections - Rear Panel

The CVXL power connections are located on the rear panel. It is suggested to understand the power connections and descriptions below to insure proper use.

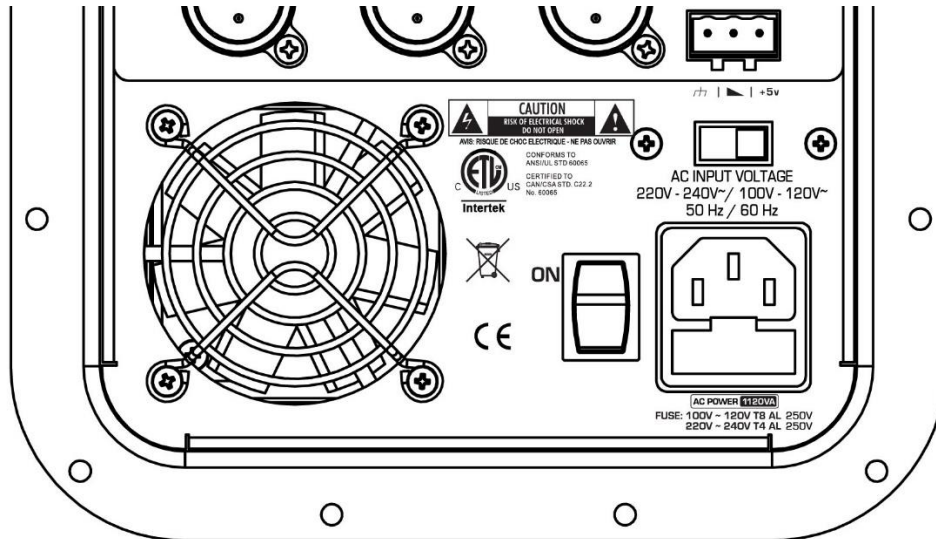

AC INPUT VOLTAGE SELECTOR

The loudspeaker can be used with 100-120V AC or 220-240V AC power supply lines. Be sure the voltage selector switch is set to the proper voltage before connecting the power cord. In addition, if the selector is adjusted from its shipped setting, be sure the proper fuse has been installed. Any failure to follow these instructions may result in damage to the fuse and/or loudspeaker.

AC POWER INLET & FUSE

The power inlet is an IEC receptacle type and should only be used with the provided, or equivalent rated, power cord.

Below the power inlet is the fuse holder that can only be accessed when the power cord is removed. Be sure to use the same or equivalent rated fuse when replacing. (See Specification section).

MAIN POWER SWITCH

The ON/OFF master switch controls the power to the loudspeaker. Be sure all connections are made and audio settings are set at a safe level before placing the loudspeaker into an 'ON' condition.

FAN

The fan is automatically controlled by the loudspeaker and provides air-flow ventilation for the internal electronics. The fan should never be blocked in order to insure proper cooling air flow to the electronics.

Using the CVXL-112 as a floor/stage monitor

The CVXL-112 can be used as a floor monitor by orienting it as shown below. This places it at a fixed 45-degree angle toward the performers. It is recommended to use **MONITOR** mode for this application, as it reduces the volume of frequencies that are prone to feedback. Be sure that the loudspeaker and cables are not located where they can become a tripping hazard. It is recommended to use right-angle XLR or right-angle ¼" jacks where possible to avoid cable binding between the loudspeaker and the stage.

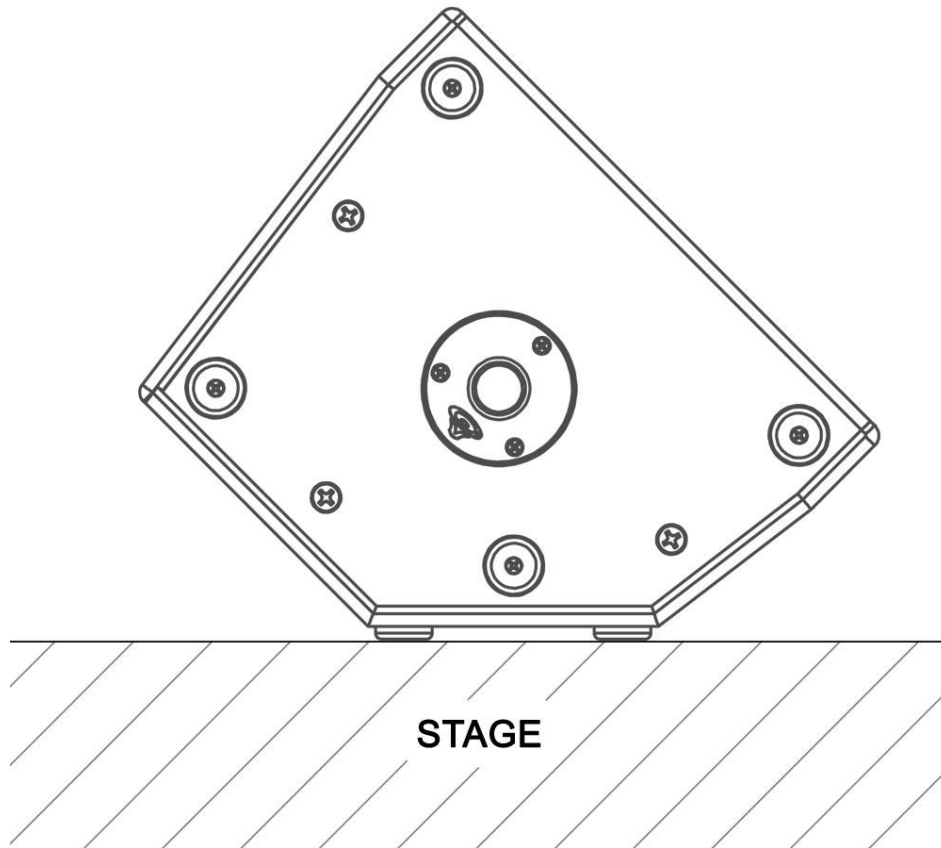

Using the pole mount - CVXL-112, CVXL-115 only



CAUTION: When using stands or poles, be sure to observe the following:

- Make sure the pole stand is capable of handling the weight of the loudspeaker. Be sure to observe all precautions as indicated by the pole stand manufacturer.
- The pole stand should be placed with its legs fully extended on a surface that is flat, level, and stable. The pole stand legs should be placed where they will not present a tripping hazard.
- Power cables and audio signal cables should be placed in a location where they will not create a tripping hazard or topple the speakers when moved or pulled.
- Before loudspeaker pole mounting, be sure to inspect all critical points for cracks, deformations, corrosion, and/or missing parts that may affect the strength and safety of the installation.
- Only use a pole stand intended for loudspeaker use.
- Avoid placing the pole stand and loudspeaker in an area of traffic to prevent accidental contact.
- In a windy environment, be sure to use additional weight (such as sand bags) on the base of the pole stand for additional stability. Do not attach banners, signage, or balloons to the pole stand or the loudspeaker.
- Consult a licensed professional engineer regarding equipment installation, and ensure that all local, state, and national regulations regarding the safety and operation of loudspeakers and related equipment are understood and followed.

Using suspension points - CVXL-112, CVXL-115, CVXL-215 only

The CVXL-112, CVXL-115, and CVXL-215 suspension points are M10 threads. The suspension points are located on all sides of the loudspeaker except on the front. Any suspension point can also be used for speaker pullback.

SUSPENSION AND PULLBACK POINTS

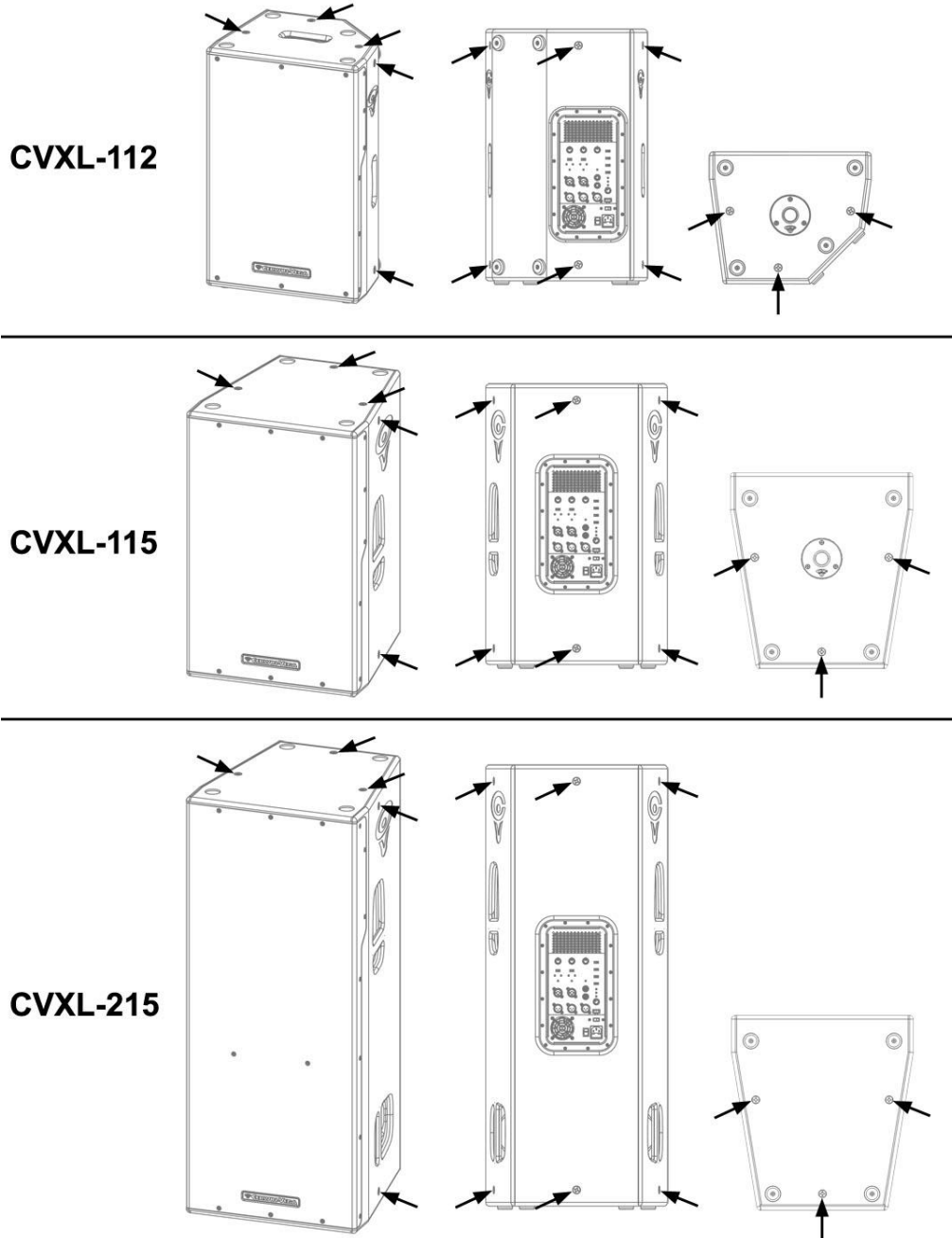

To suspend a loudspeaker, remove the M10 countersunk fly bracket screws in the fly points where you want to install M10 eye bolts. Screw in the M10 eye bolts being careful not to strip the fly bracket screw insert point. Do not remove fly bracket screws from areas where you will not install eye bolts. Ensure that either an eye bolt or a fly bracket screw is installed in all fly bracket screw insert locations.

Use only eye bolts that are professionally certified for the proper 10x load requirements. Suspending loudspeakers is serious business! Injury or death can occur if loudspeaker systems are not suspended correctly! Read and follow these instructions carefully! Speaker suspension must take place in accordance with instructions provided by Cerwin-Vega and under the supervision of a licensed, professional sound/rigging engineer or structural engineer. Only use attachments, mounts, accessories, or brackets specified by Cerwin-Vega or only specified products rated for overhead suspension. Refer all servicing to qualified personnel. Servicing is required when the apparatus has been damaged in any way.

SUSPENSION DE-RATING

Using the mounting points at an angle will de-rate the WLL (Working Load Limit) for each mounting point. Each point mounted at an angle should be de-rated according to the following formula:

$$\text{WLL} = \text{cosine}(\text{angle}) \times 500$$

Where:

Angle = degrees from vertical pull

500 = WLL for each CVXL mounting point @ vertical pull



CAUTION: When using suspension installation, be sure to observe the following:

- Loudspeaker suspension requires qualified persons who are familiar with rigging standards and practices. Any unsafe mounting of any heavy load can result in serious injury and equipment damage.
- Consult a licensed, professional engineer regarding equipment installation and ensure that all local, state and national regulations regarding the safety and operation of loudspeakers and related equipment are understood and adhered to.
- Do not attempt to suspend the loudspeakers by the handles.
- Before loudspeaker suspension, be sure to inspect all critical points for any cracks, deformations, corrosion and/or missing parts that may affect the strength and safety of the installation.
- Only use commercially-available M10 load-rated shoulder eyebolts along with rigging hardware appropriate for the actual load.
- Fittings and rigging hardware may deteriorate over extended periods of time due to wear and/or corrosion, be sure the installation is checked thoroughly by qualified personal at regular intervals.
- Cerwin-Vega cannot be held responsible for damage or injury caused by insufficient strength of the support structure or improper installation.

Do not use the pull-back point as the suspension point for a majority of the load. The pull-back points are intended for angling the loudspeaker downwards only. Note that the loudspeaker suspension points are intended for one loudspeaker only.

Application #1 - Single CVXL-112, CVXL-115, or CVXL-215

A single CVXL-112, CVXL-115, or CVXL-215 powered speaker can be used to reinforce sound for a wide variety of performances. The diagram below shows an application where a vocal microphone, an acoustic-electric guitar, and either a keyboard or media player are used together. Each individual channel volume can be adjusted to create the right balance while the main volume knob controls the overall audience volume.

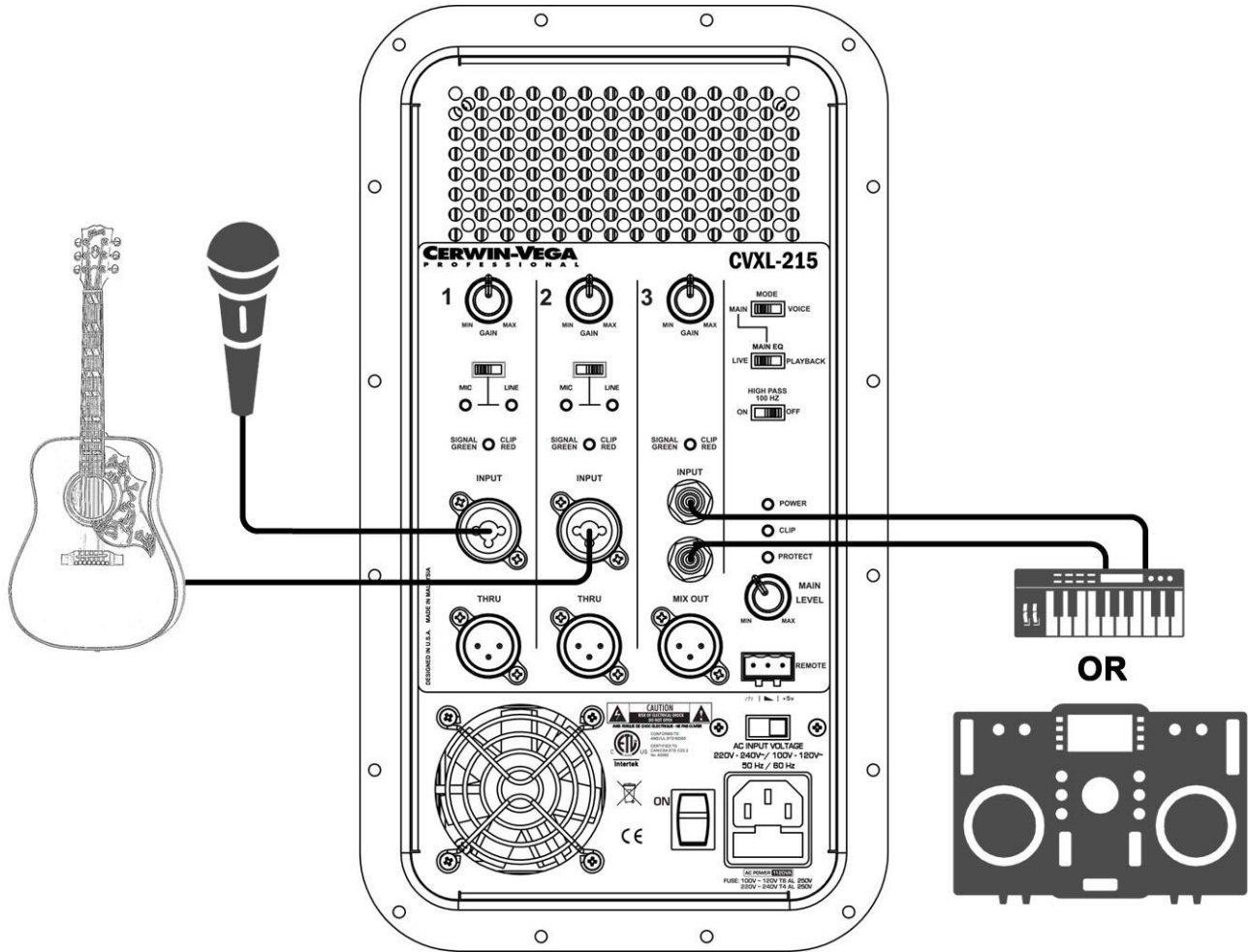

Connection	Equipment	Cable Type
Input 1 or 2	Microphone (Set switch to MIC)	XLR
Input 1 or 2	Acoustic-Electric Guitar (Set switch to LINE)	¼" TS (standard guitar cable)
Input 3	Keyboard or media player (Line Level)	Dual ¼" TS (or RCA*)

Switches	Mode	Main
	Main EQ	Live or Playback
	High Pass 100 Hz	On or Off

* Devices with RCA outputs can use INPUT 3 with RCA to ¼" TS cable or plug adapters.

Application #2 - Adding a second CVXL-112, CVXL-115, or CVXL-215

A second CVXL-112, CVXL-115, or CVXL-215 loudspeaker can easily be added using a standard XLR/mic cable as in the example below. A two speaker system can cover a wider audience and situations where more volume is needed. To add a second CVXL-112, CVXL-115, or CVXL-215 loudspeaker, connect the MIX OUTPUT of the first speaker to INPUT 1 or INPUT 2 on the second speaker then set the level and main volume to an appropriate setting on the first speaker. Be aware that the main volume on the first speaker will not change the volume on the second speaker so make sure to set the input and main volume knobs to similar settings.

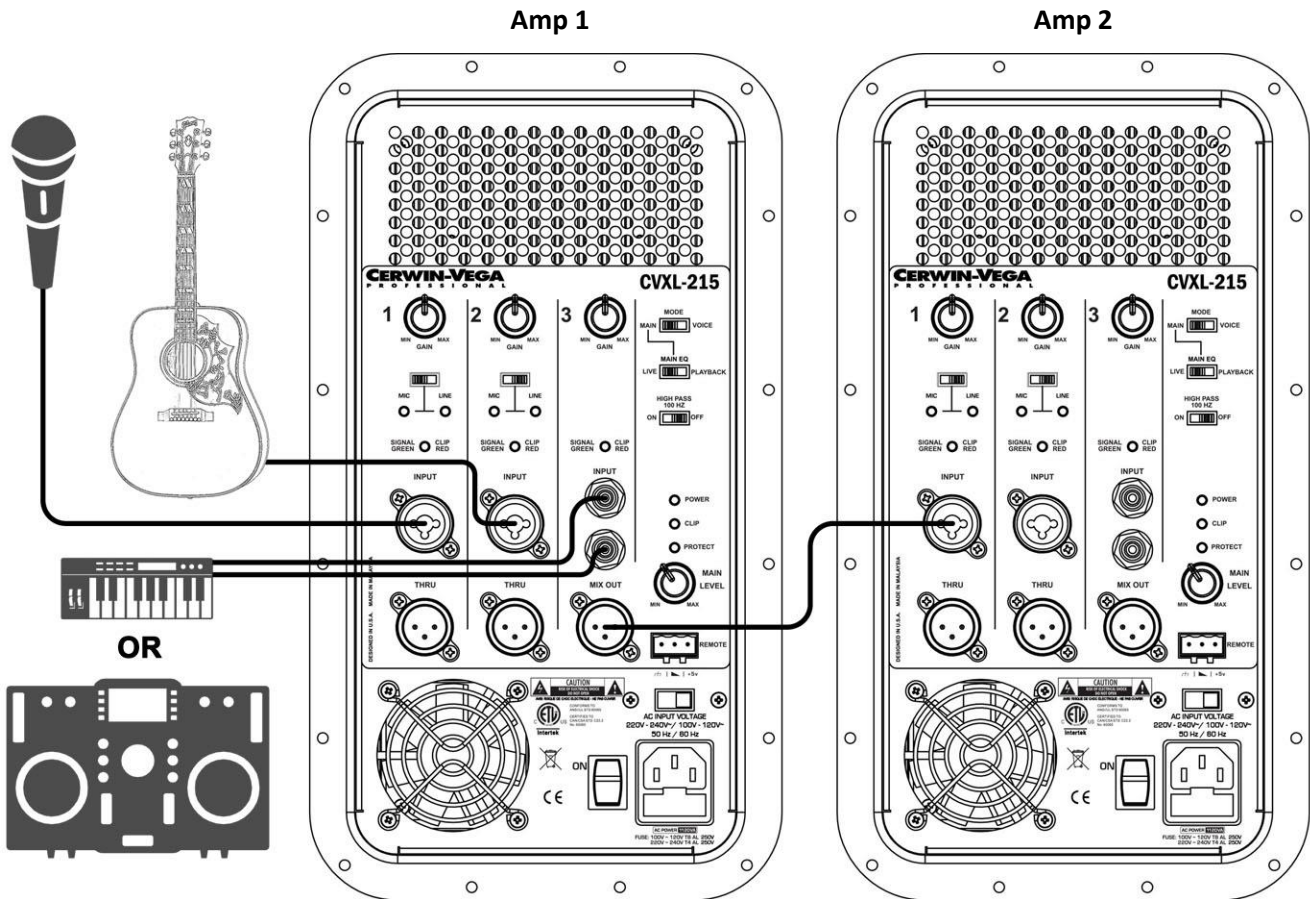

Amp	Connection	Equipment	Cable Type
1	Input 1 or 2	Microphone (Set switch to MIC)	XLR
1	Input 1 or 2	Acoustic-Electric Guitar (Set switch to LINE)	¼" TS (standard guitar cable)
1	Input 3	Keyboard or media player (Line Level)	Dual ¼" TS (or RCA*)
2	Input 1 or 2	Mix Out from Amp 1 (Set switch to LINE)	XLR or XLR to ¼" TRS

Switches (Both Amps)	Mode	Main
	Main EQ	Live or Playback
	High Pass 100 Hz	On or Off

* Devices with RCA outputs can use INPUT 3 with RCA to ¼" TS cables or plug adapters.

Application #3 - Adding a Subwoofer

For public address (PA) or DJ applications where even greater bass response is ideal, adding a single subwoofer to a pair of CVXL-112, CVXL-115, or CVXL-215 speakers offers a high powered portable solution. In the diagram below, an audio source is connected to INPUT 1 and INPUT 2 on the CVXL-118s/CVXL-218s subwoofer and then the signal is linked to the CVXL-112, CVXL-115, or CVXL-215 speakers by using the CVXL-118s/CVXL-218s THRU 1 and THRU 2 outputs. For the best sound, make sure to set the filter switches on each speaker as indicated below.

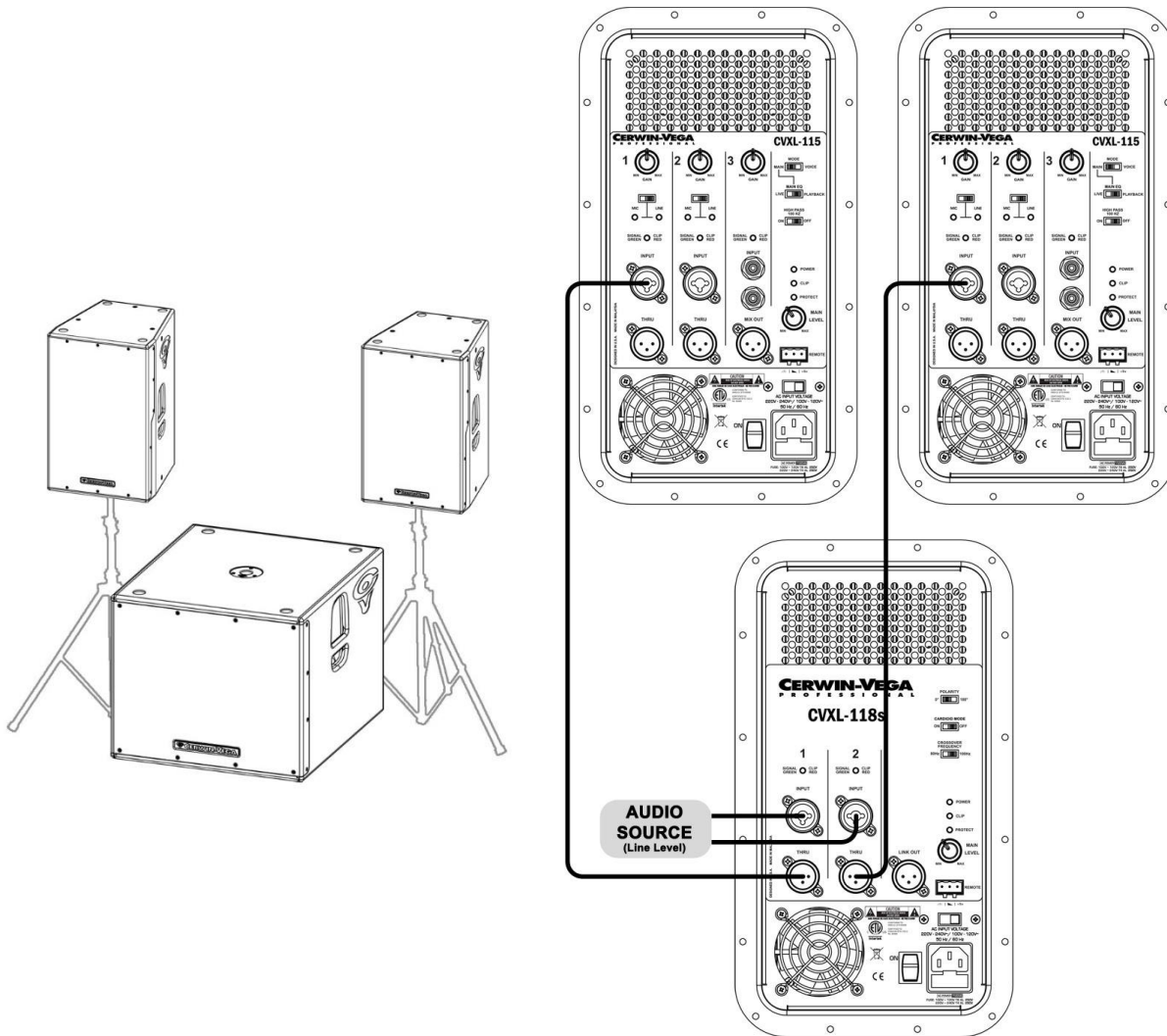

CVXL-112/115/215	Equipment	Cable Type
Input 1	From CVXL-118s/218s THRU 1 and THRU 2 outputs	XLR

CVXL-118s/218s	Equipment	Cable Type
Input 1 and 2	From Audio Source (Line Level)	XLR, 1/4" TRS, or 1/4" TS

Switches (CVXL-112/115/215)	Mode	Main
	Main EQ	Live or Playback
	High Pass 100 Hz	Off

Switches (CVXL-118s/218s)	Polarity	0°
	Cardioid Mode	Off
	Crossover Frequency	(Any)

Application #4 - Adding Two Subwoofers

For demanding applications where even greater bass response is ideal, adding a pair of subwoofers to a pair of CVXL-112, CVXL-115, or CVXL-215 speakers is a great idea. In the diagram below, an audio source is connected to INPUT 1 on each CVXL-118s/CVXL-218s subwoofer and then the signal is linked to the CVXL-112, CVXL-115, or CVXL-215 speakers by using the CVXL-118s/CVXL-218s THRU 1 outputs. For the best sound, make sure to set the filter switches on each speaker as indicated below.

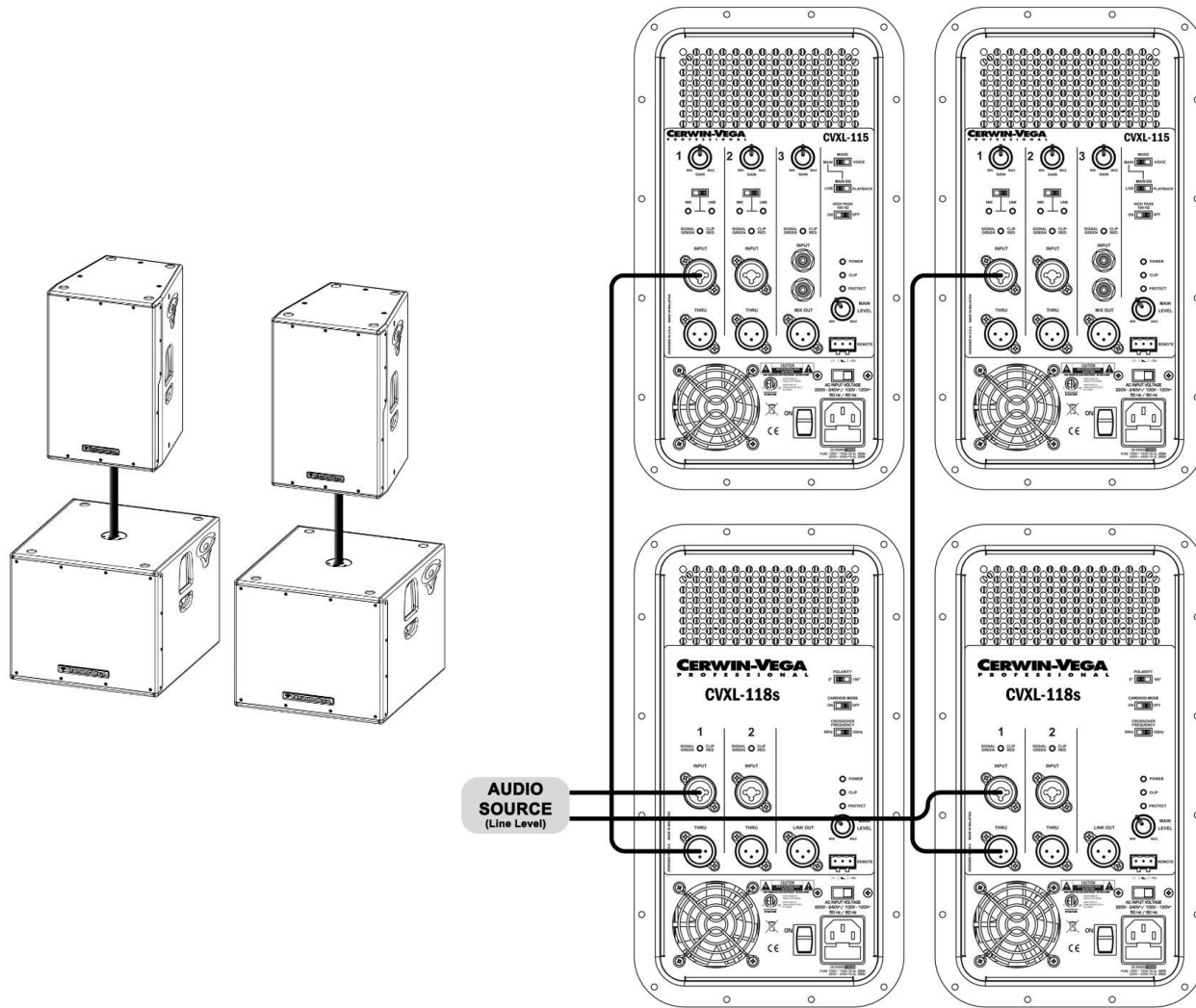

CVXL-112/115/215	Equipment	Cable Type
Input 1	From CVXL-118s/218s THRU 1 output	XLR

CVXL-118s/218s	Equipment	Cable Type
Input 1	From Audio Source (Line Level)	XLR, ¼" TRS, or ¼" TS

Switches (CVXL-112/115/215)	Mode	Main
	Main EQ	Live or Playback
	High Pass 100 Hz	Off

Switches (CVXL-118s/218s)	Polarity	0°
	Cardioid Mode	Off
	Crossover Frequency	(Any)

Application #5 - Subwoofer Cardioid Mode - Two Subwoofers

For applications where multiple subwoofers are required but are located close to the performers, CVXL subwoofers feature a cardioid mode setting which helps to reduce subwoofer levels behind the stage side while still achieving good audience coverage. The diagram and tables below show how to connect two CVXL-118s/CVXL-218s subwoofers using cardioid mode.

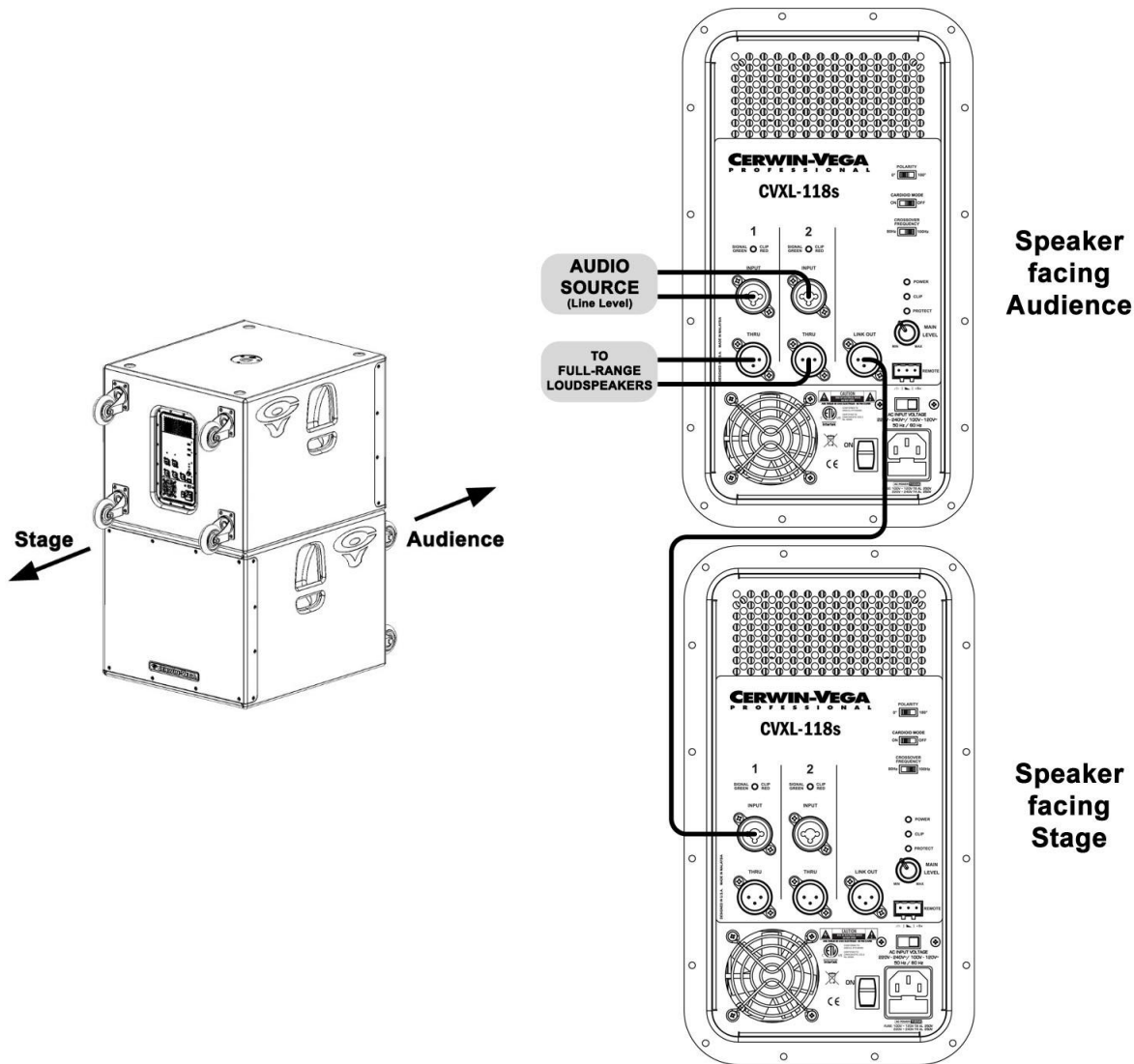

Subwoofer	Connection	Equipment	Cable Type
Audience	Input 1 and/or 2	From Audio Source (Line Level)	XLR, ¼" TRS, or ¼" TS
Audience	Thru 1 and/or 2	To Full-Range Loudspeakers	XLR
Stage	Input 1 or 2	Link Out from Audience facing Subwoofer	XLR

Switches (Audience Sub)	Polarity	0°
	Cardioid Mode	Off
	Crossover Frequency	(Any)

Switches (Stage Sub)	Polarity	0°
	Cardioid Mode	On
	Crossover Frequency	(Any)

Application #6 - Subwoofer Cardioid Mode - Three Subwoofers

For applications where multiple subwoofers are required but are located close to the performers, CVXL subwoofers feature a cardioid mode setting which helps to reduce subwoofer levels behind the stage side while still achieving good audience coverage. The diagram and tables below show how to connect three CVXL-118s/CVXL-218s subwoofers using cardioid mode.

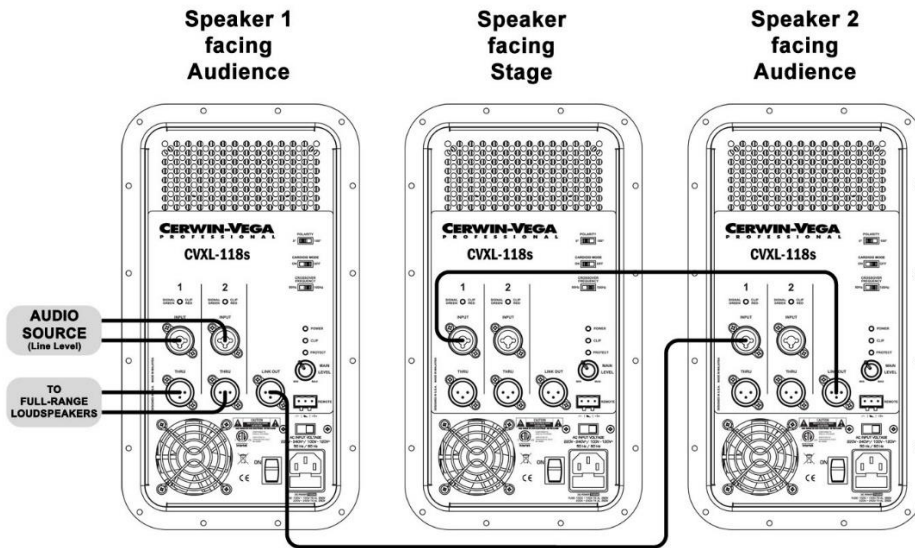
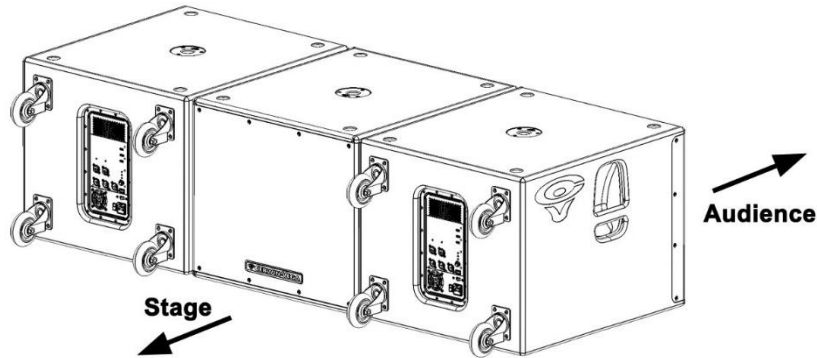

Subwoofer	Connection	Equipment	Cable Type
Audience 1	Input 1 and/or 2	From Audio Source (Line Level)	XLR, ¼" TRS, or ¼" TS
Audience 1	Thru 1 and/or 2	To Full-Range Loudspeakers	XLR
Stage	Input 1 or 2	Link Out from Audience 2 facing Subwoofer	XLR
Audience 2	Input 1 or 2	Link Out from Audience 1 facing Subwoofer	XLR

Switches (Audience Subs)	Polarity	0°
	Cardioid Mode	Off
	Crossover Frequency	(Any)

Switches (Stage Sub)	Polarity	0°
	Cardioid Mode	On
	Crossover Frequency	(Any)

Application #7 – Daisy-Chain

Some events may require several CVXL-112, CVXL-115, or CVXL-215 speakers spread across a long distance or a large stage front to provide adequate sound reinforcement for the entire audience. If there are multiple sources connected to the first speaker, the Mix Out from the first speaker should be used to daisy-chain to the next CVXL-112, CVXL-115, or CVXL-215. Any additional speakers should connect Input 1 to Mix Out of the previous speaker.

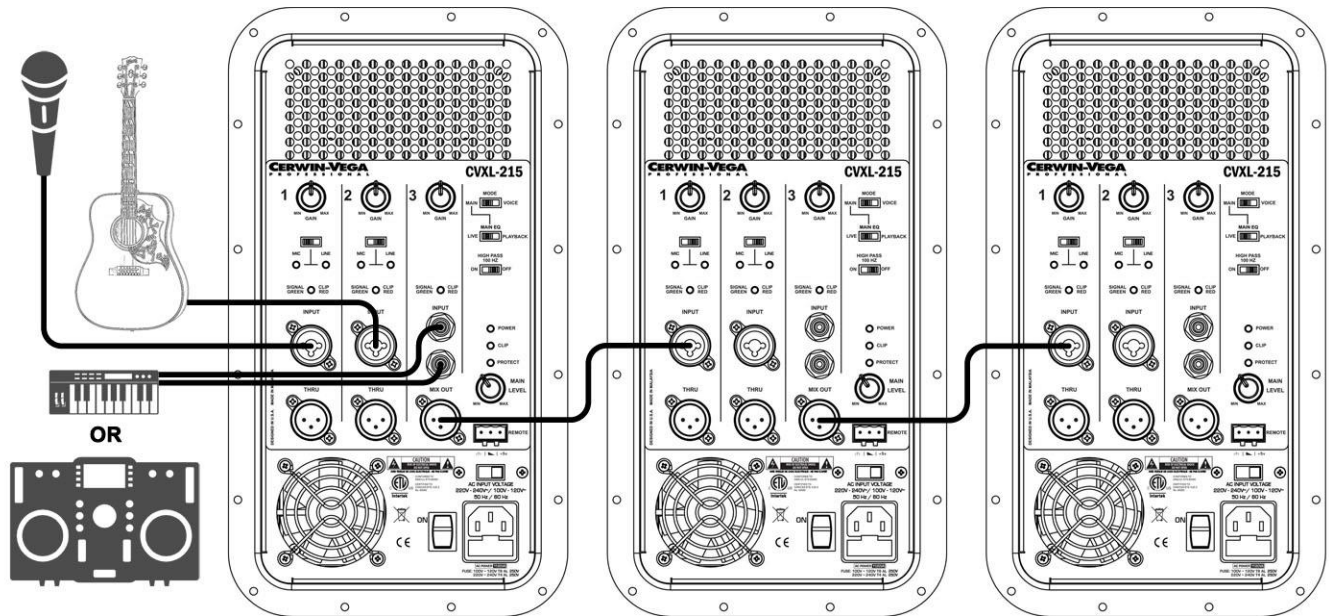

Connection	Equipment	Cable Type
Input 1 or 2	Microphone (Set switch to MIC)	XLR
Input 1 or 2	Acoustic-Electric Guitar (Set switch to LINE)	XLR
Input 3	Keyboard or media player	Dual ¼" TS (or RCA*)
MIX OUTPUT	To CVXL-112/115/215 next in daisy-chain (Input 1, Input switch set to LINE)	XLR, ¼" TRS, or XLR to ¼" TRS

Switches (All Amps)	Mode	Main
	Main EQ	Live or Playback
	High Pass 100 Hz	Off

* Devices with RCA outputs can use INPUT 3 with RCA to ¼" TS cable or plug adapters.

Application #8 – Adding a CVXL-112 as a Stage Monitor

In a live performance, a performer may wish to have a stage monitor to help hear the sound of the performance better. The diagram below shows a CVXL-112 used as a stage monitor for the performer plus two CVXL-215 speakers (daisy-chained) for the audience. CVXL-112 or CVXL-115 speakers can also be used for the audience. The performer(s) may have a different mix requirement than the audience which means all the THRU outputs from the performer(s) must be taken to the first loudspeaker used to cover the audience. At the first loudspeaker, the input levels can be mixed to the preferred presentation for the audience. The performer's monitor can be mixed to the performer's specific requirements without affecting what the audience hears.



NOTE: Careful positioning of the monitor loudspeaker is required as the proximity to the microphone is susceptible to feedback. As a general rule, never point the microphone towards the loudspeaker.

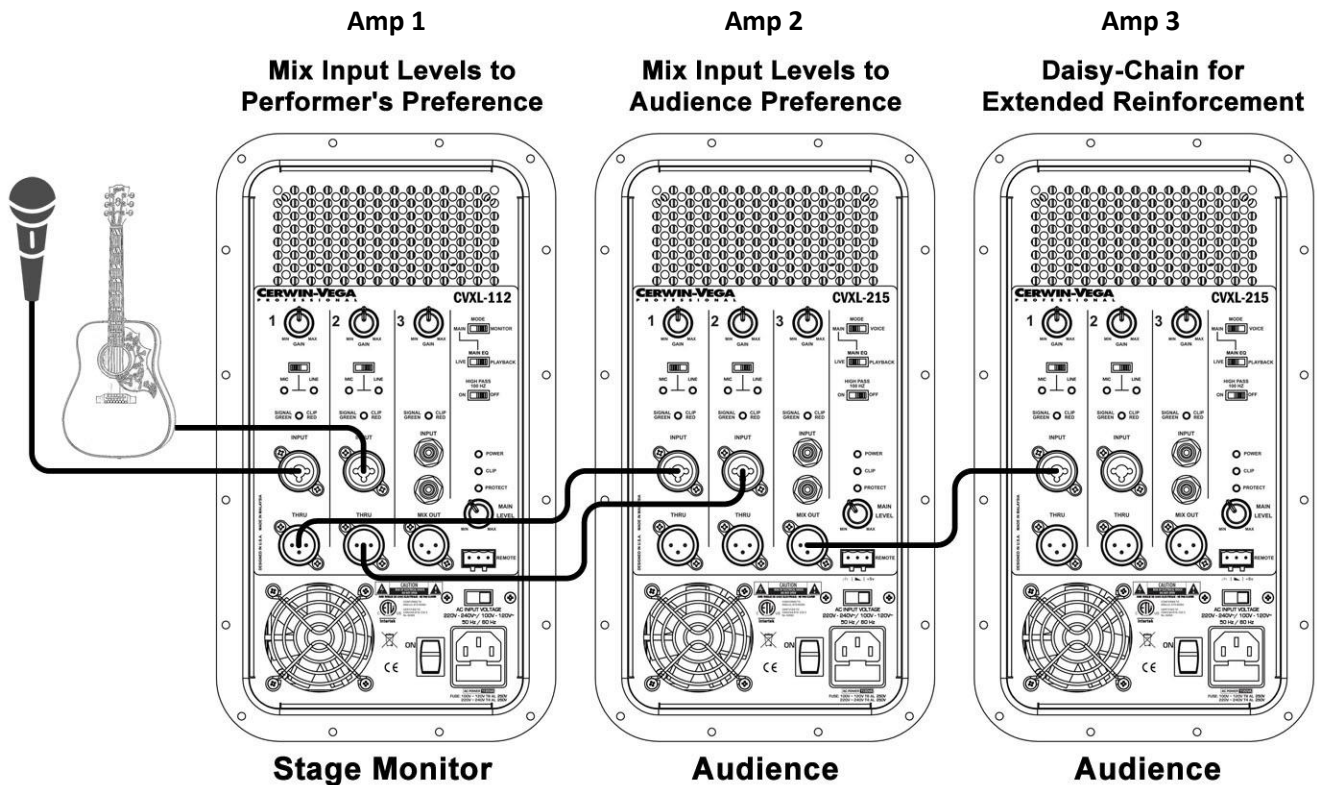

Amp	Connection	Equipment	Cable Type
1	Input 1 or 2	Microphone (Set switch to MIC)	XLR
1	Input 1 or 2	Acoustic-Electric Guitar (Set switch to LINE)	¼" TS (standard guitar cable)
2	Input 1 and 2	Thru 1 and 2 from Amp 1 (Set switches to MIC and LINE)	XLR
3	Input 1 or 2	Mix Out from Amp 2 (Set switch to LINE)	XLR

Switches (Stage Monitor)	Mode	Monitor
	Main EQ	Live or Playback
	High Pass 100 Hz	On or Off

Switches (Audience)	Mode	Main
	Main EQ	Live or Playback
	High Pass 100 Hz	Off

Application #9 – Large Venue/Front of House

In larger venues, the Front of House engineer has control of the entire sound reinforcement system using the console mixer. The diagram below shows how a console mixer interfaces with the performers' on-stage audio equipment with several CVXL-112 used as monitors and CVXL-115, CVXL-215, and CVXL-218s speakers directed towards the audience.

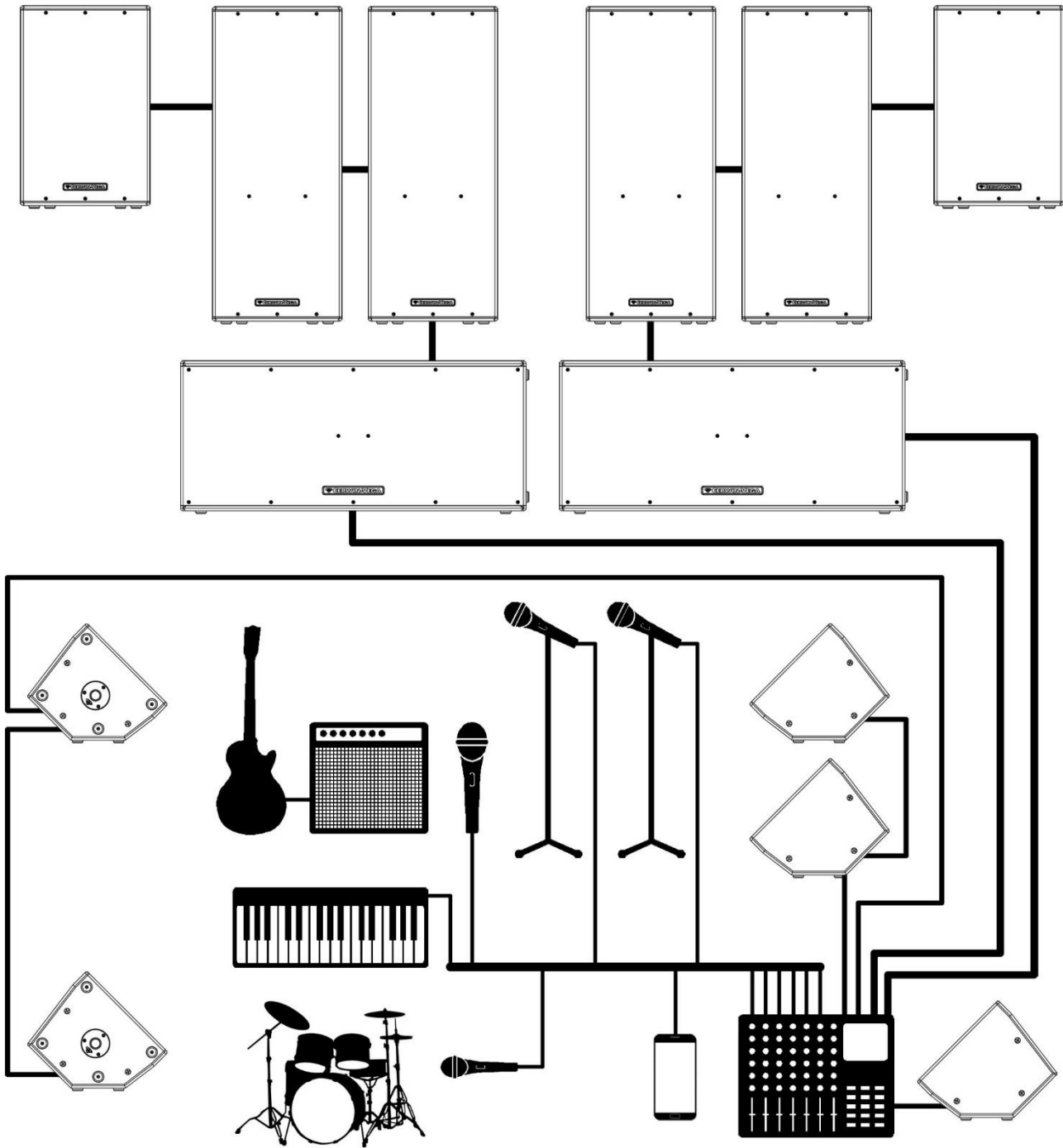

Protective Grill

All CVXL model loudspeakers are shipped with the grill attached. It is recommended to leave the grill in place as it will prevent any accidental damage to the drivers that may result during transportation, setup, and general use.

In the event that the grill needs to be removed, simply remove the hex-head screws around the edges of the grill. Remove the grill slowly to avoid damaging the gasket. When replacing the grill, be sure the gasket is in place and all fasteners are secured tightly to prevent rattling during general use.

Remote Main Volume

The 3-pin terminal connector plug allows any CVXL loudspeaker main volume level to be controlled from a remote location through signal wires and an external device (not included). The signal wire passes only a voltage level and not the actual audio signal. A single device can control the main volume of multiple units when connected correctly. The potentiometer should be 10 k Ohm and specified to support numerous rotations as required for volume control use.



NOTE: Do not use the remote main volume connection for anything other than volume control through the external device. Failure to follow this warning may result in damage to the loudspeaker.

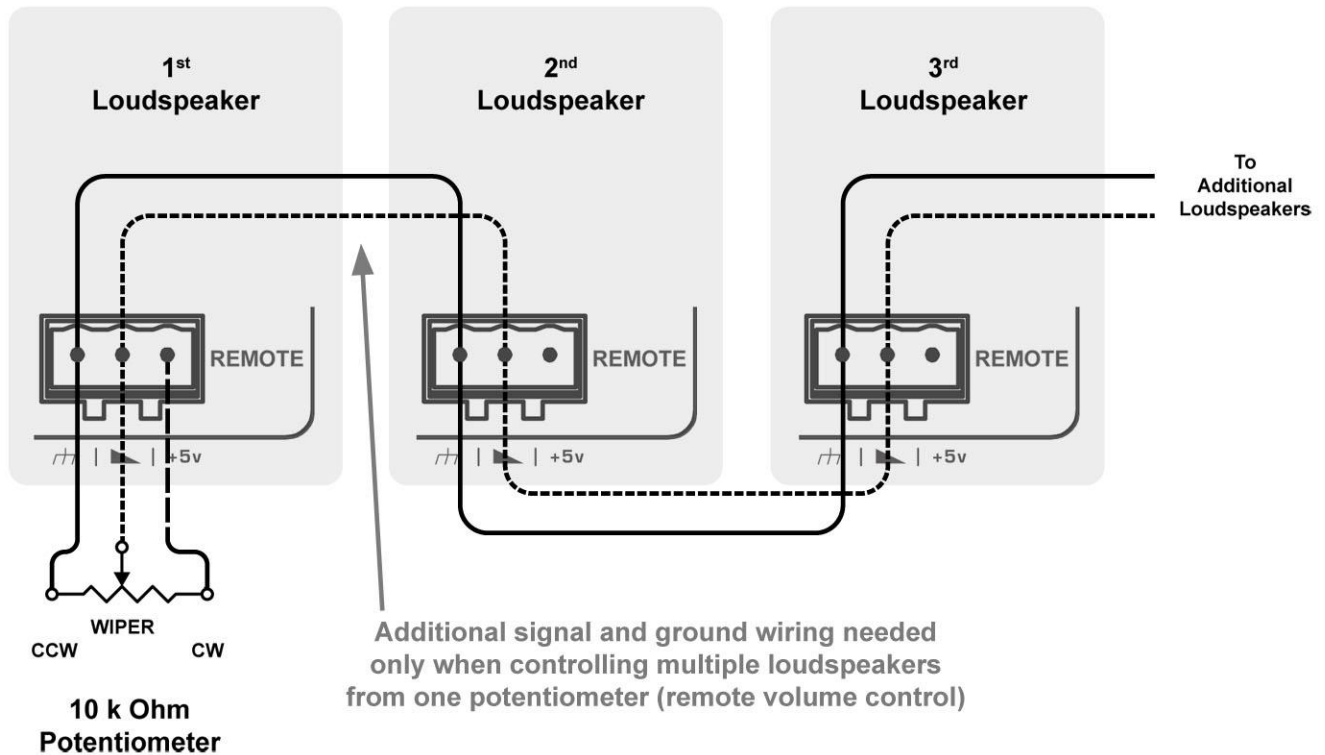

Troubleshooting

Problem	Cause	Solution
No Sound	No connection to active AC power	Verify that the loudspeaker is connected to an active AC power source. Various outlets may need to be switched on. Use a lamp as another way to be sure the AC power source is active.
	Incorrect power switch position	Verify that the power switch on the back of the loudspeaker is set to the ON position.
	Incorrect LEVEL setting.	Adjust the LEVEL to a setting where sound can be heard.
	Inactive audio source, inadequate volume, or poor connection	<ul style="list-style-type: none"> • Verify that the audio equipment is turned on and that its level is set to output an audio signal at an audible volume level. • Verify that the cable connection from the audio source output to the loudspeaker input is correct. • Verify that the MUTE switch on the audio mixer is disengaged. • Verify that an external power source is used with microphones that require phantom power.
No Power	No connection to active AC power	Verify that the loudspeaker is connected to an active AC power source. Various outlets may need to be switched on. Use a lamp as another way to be sure the AC power source is active.
	Incorrect power switch position	Verify that the power switch on the back of the loudspeaker is set to the ON position.
	Incorrect AC power source voltage	Verify that the AC power source is not too high or too low.
	Blown loudspeaker fuse	Disconnect all power connections, and inspect and replace (if necessary) the fuse located on the rear of the loudspeaker.
Shutdown	Loudspeaker self-protection enabled	<ul style="list-style-type: none"> • Avoid placing the loudspeaker near a heat source or in direct sunlight. • Avoid using an audio source with clipped and/or distorted input signal.

Troubleshooting (continued)

Problem	Cause	Solution
Bad Sound	Incorrect equipment settings, causing distortion	<ul style="list-style-type: none"> • Check the meters on the external mixing console to ensure that the signal is not being clipped by the mixer. If the levels from the mixer are too high, correct the gain structure of the console, first by lowering the pre-amplifier trim (input sensitivity). If this does not lower the signal level sufficiently, then lower the channel faders. If the level is still too high, then lower the master bus; however, a clipped input is most likely the source of the distortion. It is important to check every active input channel on the console to ensure that each input trim is set correctly for each source. • If the signal sources are plugged directly into the speaker, make sure that the input levels are not turned up too high. If the signal indicator LED is turning red on any channel, this indicates that the input on that channel is clipping and that the input level needs to be lowered. It is also possible that the source level needs to be lowered. If distortion is still audible after lowering the source level and input level, then lower the master volume. • Check that the audio source and/or mixer do not have excessive bass or treble added to the mix, as overdriven EQs can clip, causing audible distortion.
Cable connections are bad.		Verify that all connections are good. Verify that the connectors are clean and free of any residue buildup. Verify that the insulation jackets on all cables have not been torn or crushed.
Rattling Sounds		Be sure that the rattling sounds do not come from the caster wheels (subwoofer only), loudspeaker stands, or any furniture or fixtures located near the system.
Bad AC mains cable location		Avoid using an AC power source that is connected to a light dimmer. Use an AC filter box, or use a different AC circuit. Avoid routing the audio signal cables along other power cables, transformers, or signal cables to prevent interference.
Ground loop hum		Turn all volume and input levels to their minimum settings to verify there is no hum coming from the connected audio equipment. If the hum is still present, then remove all audio cable connections; if the hum disappears, then there is a potential ground loop problem. Ground lifting the signal cable (with a direct box or coupling transformer) is the safest way to eliminate ground loops within sound setups. Plug all audio equipment AC power connections into the same outlet, which shares a common ground (make sure that the outlet is capable of supporting the power draw of the equipment to avoid overloading the circuit). Verify that the distance between AC power source and common ground is as short as possible.
Equipment hiss		Use a balanced connection to take advantage of the best noise rejection. Plug all audio equipment AC power connections into the same outlet which shares a common ground (make sure that the outlet is capable of supporting the power draw of the equipment to avoid overloading the circuit).

Care and Maintenance

Before any cleaning or maintenance, be sure the loudspeaker is unplugged, turned off, and that all cables have been removed. Be sure to prevent any moisture coming into the openings of the speaker.

The loudspeaker can be maintained cosmetically by using a dry cloth. Avoid using cleaning chemicals, as they may harm the finish of the loudspeaker. A direct burst of air should be avoided since it could harm the drivers or force debris into the enclosure.

When storing the loudspeaker, be sure to avoid areas prone to accidental flooding and excess dust buildup. It is suggested to cover the loudspeaker while it is placed in storage or being transported.

Cable Connections

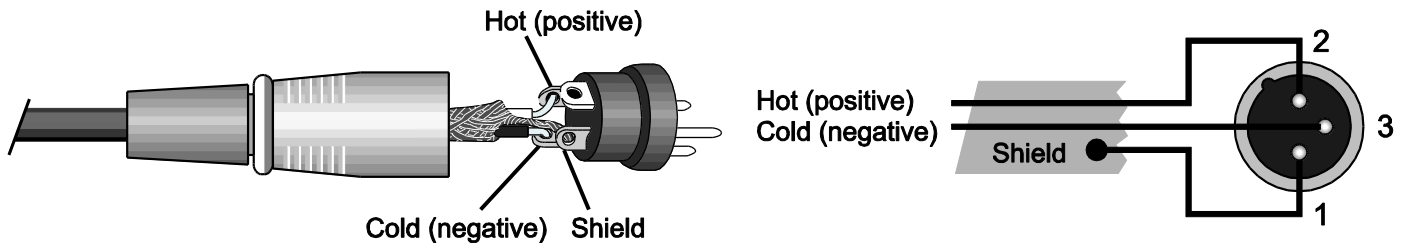

XLR Balanced Input

1/4" TRS Balanced

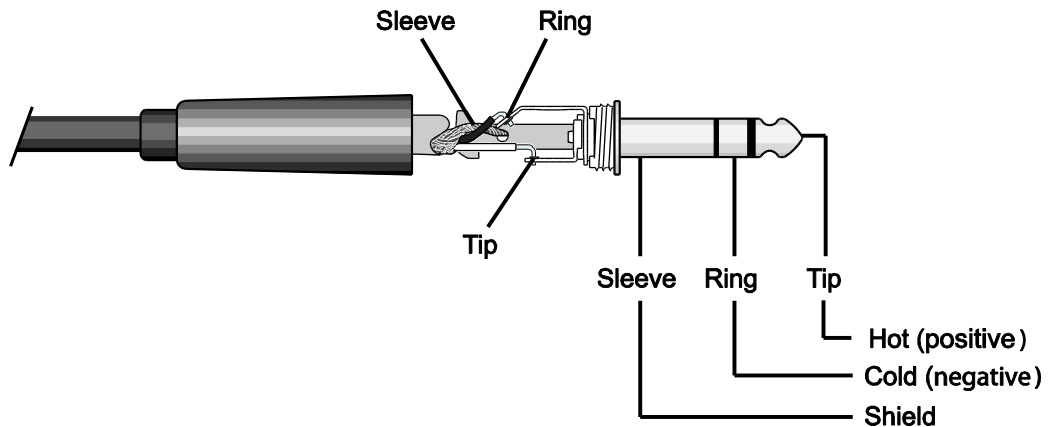

1/4" TS Unbalanced

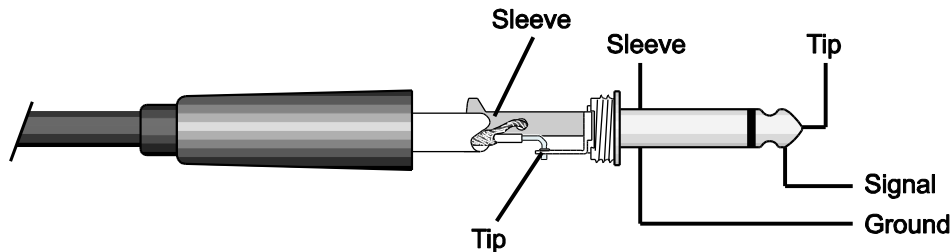

REMOTE DEVICE DESCRIPTION

CABLE

REMOTE SIDE OF CABLE (Connector Type)

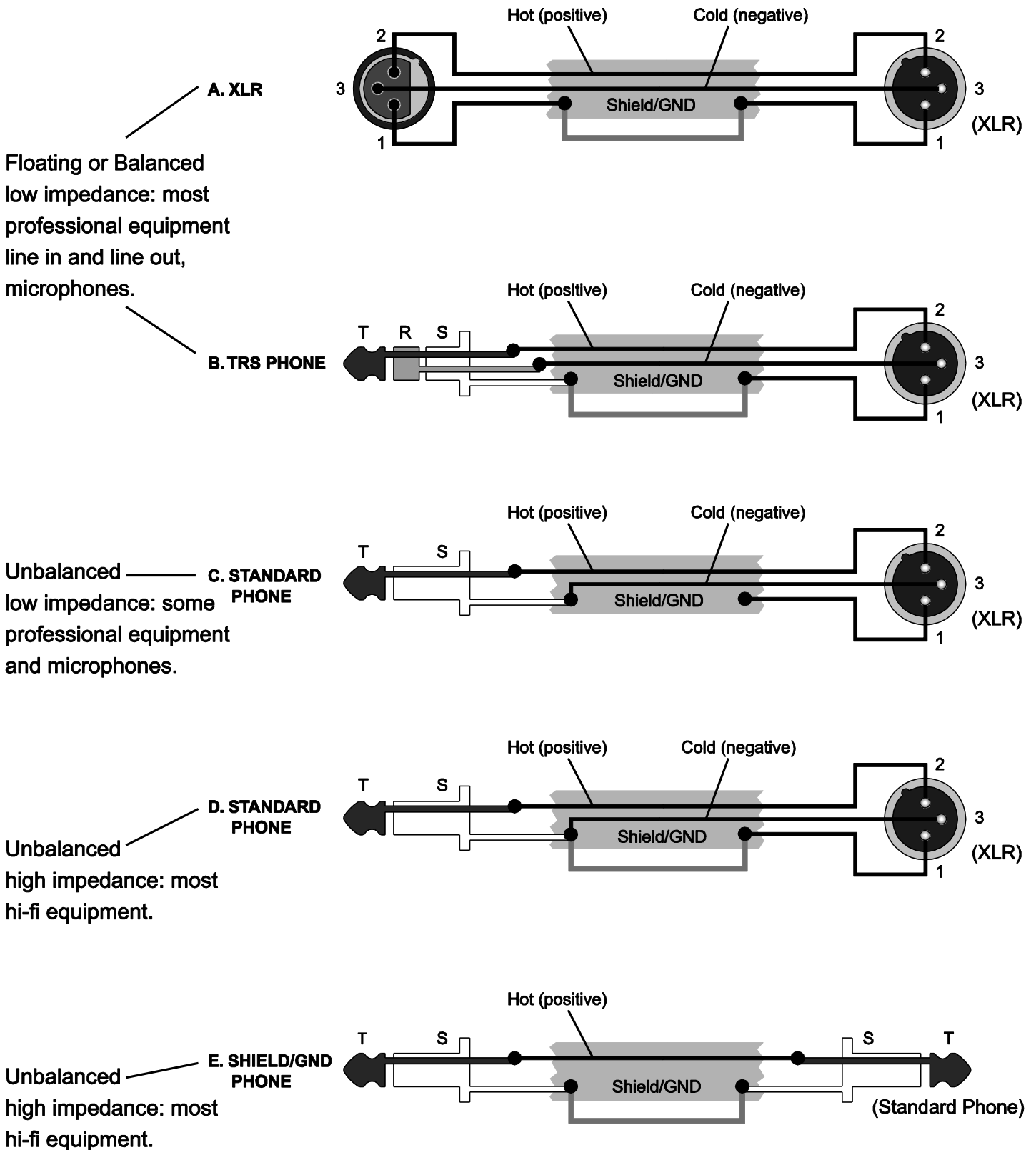

Warranty

Thank you for choosing one of Gibson Pro Audio's brands (Stanton, KRK, or Cerwin-Vega).

Your satisfaction is extremely important to us. We proudly stand behind the quality of our work and appreciate that you put your trust in us. Registering your merchandise will help us guarantee that you are kept up to date on our latest advances.

To Register Merchandise Purchased from an Authorized Gibson Pro Audio Dealer in the U.S.:

Please go to: <http://www.gibson.com> and register online.

Or you may send your warranty card to:

Gibson Customer Service

309 Plus Park Blvd.

Nashville, TN 37217

If you have any questions you may contact customer service at:

1-800-4GIBSON (1-800-444-2766)

e-mail: service@gibson.com

FOR MERCHANDISE PURCHASED FROM AN AUTHORIZED GIBSON PRO AUDIO DISTRIBUTOR OUTSIDE OF THE US, PLEASE CONTACT THE DISTRIBUTOR FROM WHOM YOU PURCHASED YOUR MERCHANDISE FOR TO REGISTER YOUR WARRANTY AND FOR HANDLING AND RESOLUTION OF ALL WARRANTY-RELATED ISSUES.

Gibson Pro Audio Warranty

If at any time your Gibson Pro Audio product (which includes Stanton, KRK, or Cerwin-Vega brands) malfunctions as a result of faulty materials or workmanship, Gibson Pro Audio or one of Gibson Pro Audio's Authorized Service Centers in the US will repair the defect(s) or replace the merchandise as it deems appropriate at its sole discretion.

Warranty Period (from date of Purchase as listed on the Bill of Sale):

Stanton

One (1) year for all Stanton products

KRK

Three (3) years for all studio monitors

One (1) year for all headphones and computer audio devices, including room-correction devices

Cerwin-Vega

Five (5) years for all passive speaker systems

Three (3) years for all active speaker systems

Three (3) years for all mixers

Gibson will warrant all replacement parts and repairs for ninety (90) days from the date of original shipment.

In the unlikely event that your merchandise is destroyed, lost, or damaged beyond repair while in the possession of Gibson or one of Gibson Pro Audio's Authorized Service Centers for repair, Gibson will replace that merchandise with one of the same or most similar style of a value not more than the original purchase price of your merchandise. Any insurance covering the merchandise, including but not limited to collector's value insurance, must be carried by the owner at the owner's expense.

For the fastest and safest merchandise return, please use the original shipping carton and packaging materials. Gibson cannot be responsible for any damages incurred during the shipping process due to poor or inadequate packing.

THIS WARRANTY IS EXTENDED TO THE ORIGINAL RETAIL PURCHASER ONLY AND MAY NOT BE TRANSFERRED OR ASSIGNED TO SUBSEQUENT OWNERS. TO VALIDATE YOUR WARRANTY, AND AS A CONDITION PRECEDENT TO WARRANTY COVERAGE HEREUNDER, YOU MUST REGISTER YOUR WARRANTY WITHIN FIFTEEN (15) DAYS FOLLOWING THE ORIGINAL DATE OF PURCHASE. YOUR PROOF OF PURCHASE OR SALES RECEIPT MUST ACCOMPANY ALL REQUESTS FOR WARRANTY COVERAGE.

This warranty is subject to the following limitations:

THIS WARRANTY DOES NOT COVER

1. Any merchandise that has been altered or modified in any way or upon which the serial number has been tampered with or altered.
2. Any merchandise whose warranty card has been altered or upon which false information has been given.
3. Any merchandise that has been damaged due to misuse, negligence, or improper operation.
4. Any merchandise that has been damaged by accident, flood, fire, lightning, or other acts of nature.
5. Shipping damage of any kind.
6. Any merchandise that has been subjected to extremes of humidity or temperature.
7. Any merchandise that has been purchased from an unauthorized dealer, or upon which unauthorized repair or service has been performed.

GIBSON MAKES NO OTHER EXPRESS WARRANTY OF ANY KIND WHATSOEVER. ALL IMPLIED WARRANTIES, INCLUDING WARRANTIES OF MERCHANTABILITY AND FITNESS FOR A PARTICULAR PURPOSE, EXCEEDING THE SPECIFIC PROVISIONS OF THIS WARRANTY ARE HEREBY DISCLAIMED AND EXCLUDED FROM THIS WARRANTY. SOME STATES AND/OR COUNTRIES DO NOT ALLOW THE EXCLUSION OR LIMITATION OF IMPLIED WARRANTIES SO THAT THE ABOVE MAY NOT APPLY TO YOU.

GIBSON SHALL NOT BE LIABLE FOR ANY SPECIAL, INDIRECT CONSEQUENTIAL, INCIDENTAL OR OTHER SIMILAR DAMAGES SUFFERED BY THE PURCHASER OR ANY THIRD PARTY, INCLUDING WITHOUT LIMITATION, DAMAGES FOR LOSS OF PROFITS OR BUSINESS OR DAMAGES RESULTING FROM USE OR PERFORMANCE OF THE MERCHANDISE, WHETHER IN CONTRACT OR IN TORT, EVEN IF GIBSON OR ITS AUTHORIZED REPRESENTATIVE HAS BEEN ADVISED OF THE POSSIBILITY OF SUCH DAMAGES, AND GIBSON SHALL NOT BE LIABLE FOR ANY EXPENSES, CLAIMS, OR SUITS ARISING OUT OF OR RELATING TO ANY OF THE FOREGOING.

FOR MERCHANDISE PURCHASED FROM AN AUTHORIZED GIBSON PRO AUDIO DISTRIBUTOR OUTSIDE OF THE US, PLEASE CONTACT THE DISTRIBUTOR FROM WHOM YOU PURCHASED YOUR MERCHANDISE FOR THE HANDLING AND RESOLUTION OF ALL WARRANTY ISSUES. FOR THESE PURCHASES, THE ABOVE-DESCRIBED WARRANTY IS NOT APPLICABLE.

How to Obtain Warranty Service

Warranty service outside the United States

To initiate a warranty repair, please contact the Authorized Gibson Pro Audio distributor from whom you purchased your merchandise and follow the distributor's return/warranty policy.

Warranty service for merchandise purchased from an authorized Gibson Pro Audio dealer in the U.S.

In the event of malfunction of your Gibson Pro Audio merchandise, the Dealer or Owner must call Customer Service at 1-800-4GIBSON (1-800-444-2766), and obtain a Return Authorization number from the customer service agent. No merchandise may be returned to Gibson without such prior Return Authorization, and the Return Authorization number must be written on the outside of the shipping package. The Customer Service agent will provide the address and additional shipping instructions. The owner must ship the merchandise with freight and insurance pre-paid to the address provided by the customer service representative. Only Authorized Gibson Pro Audio Service Centers may perform warranty service; any service performed by unauthorized persons will void this warranty. Gibson disclaims liability for defects or damage caused by services performed by unauthorized persons or non-warranty service not performed by Gibson or an Authorized Gibson Pro Audio Service Center.

When contacting Gibson, you must include a complete written description of the malfunction of the merchandise. If non-warranty work is required or recommended, a quotation will be issued that must be approved by you before any non-warranty work is commenced. You should consider quotations obtained for non-warranty work immediately and advise the Authorized Gibson Pro Audio Service Center or Gibson of your decision. You are not required to purchase non-warranty work in order to obtain service on materials covered by this warranty. Following its inspection of merchandise upon its arrival, Gibson or the Authorized Gibson Pro Audio Service Center will advise you or your dealer of the approximate date of completion. The repaired merchandise or part will be returned to you or your dealer, freight collect insured.

No representative or other person is authorized to assume for Gibson any liability except as stated in this warranty. This warranty gives you specific rights which vary from state to state and country to country.

For further information, write

Customer Service Dept.,
Gibson Customer Service
309 Plus Park Blvd.
Nashville, TN 37217

Or call

1-800-4GIBSON (1-800-444-2766)